

6mm x 200mm min. FRP bond on Outside

SECTIONAL JOINT DETAIL A
SCALE 1/25

Parts List			
ITEM	QTY	PART NUMBER	DESCRIPTION
1	1	C-COLLAR-30IN	30"D COLLAR
2	4	LIFT-LUG-8-10	LIFT LUG
3	1	SEAM-10FT	SEAM
4	4	C-RIB-GUIDE	STRUCTURAL RIB W/ ANCHOR GUIDE
5	8	C-RIB	STRUCTURAL RIB

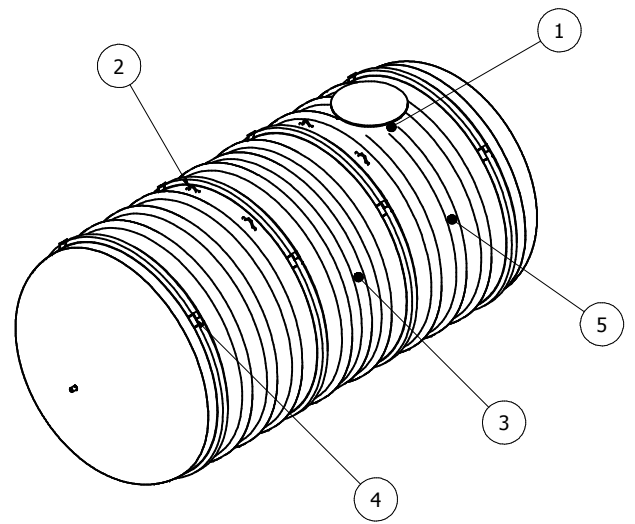

OPTIONAL	PARTS
30"X12" EXTENSION	ANCHORS
30"X30" EXTENSION	FOAM INSULATION
30"X60" EXTENSION	LOCK BAR
30"X84" EXTENSION	OPTIONAL FITTING(S)
ALARM	PUMP STAND

DRAWN	MPS	2/27/2008
CHECKED		
QA		
MFG		
DCL		
APPROVED		
DCL		
WEIGHT	1,477 kg (3,250 lbs)	LENGTH
OVERALL CAPACITY	45,460L (10,000 IG, 12,000 USG)	22' 1"

TITLE
BX1.0000W UNDERGROUND FIBREGLASS WATER CISTERN



Drinking Water NSF/ANSI 61

SIZE	C	DWG NO	BX1.0000W	REV	1
------	---	--------	-----------	-----	---

SCALE

SHEET 1 OF 1