

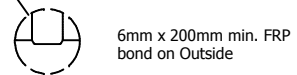

Parts List			
ITEM	QTY	PART NUMBER	DESCRIPTION
1	1	C-COLLAR-30IN	30"D COLLAR
2	1	C-LID-30IN-STD	30"D STANDARD LID
3	4	LIFT-LUG-8-10	LIFT LUG
4	4	C-RIB-GUIDE	STURUCTURAL RIB WITH ANCHOR GUIDE
5	11	C-RIB	STRUCTURAL RIB
6	1	C-SEAM-10FT	SEAM

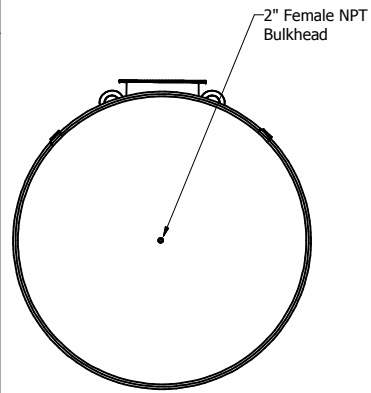
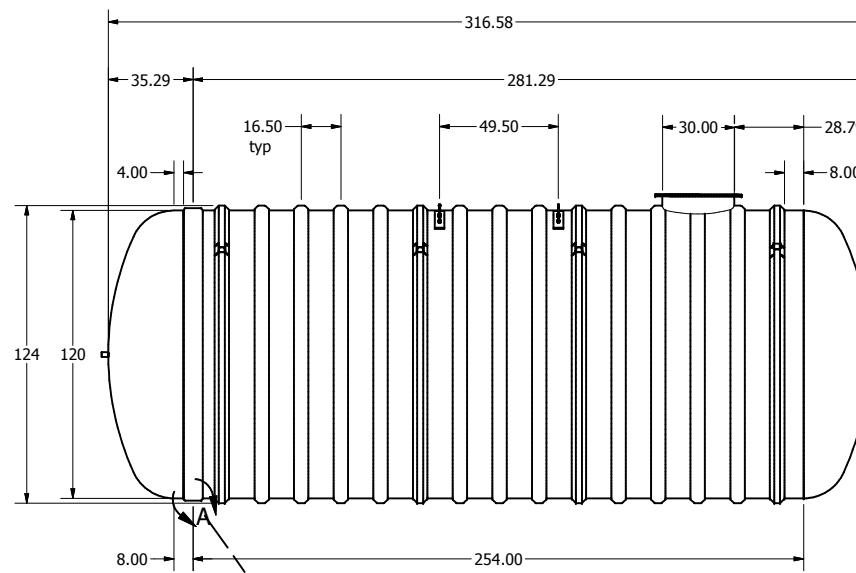
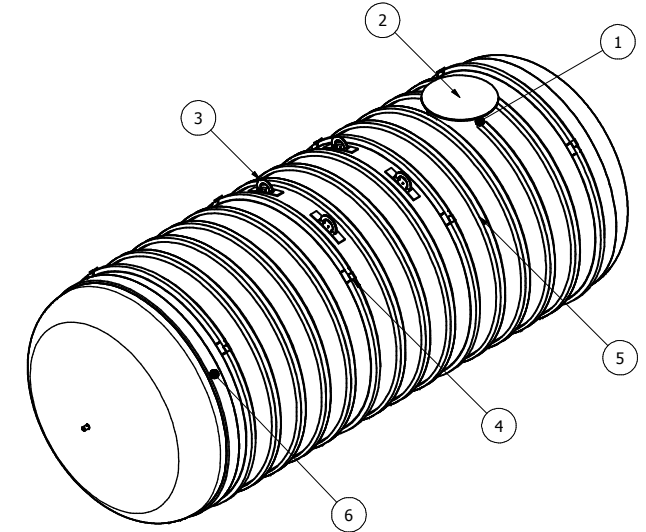
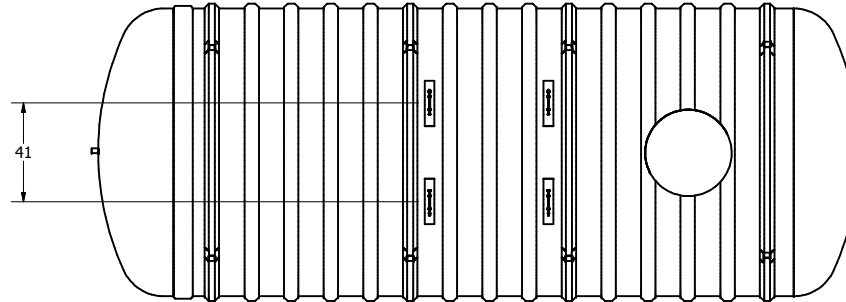

SECTIONAL JOINT DETAIL A
SCALE 1/25

OPTIONAL	PARTS
30"X12" EXTENSION	ANCHORS
30"X30" EXTENSION	FOAM INSULATION
30"X60" EXTENSION	LOCK BAR
30"X84" EXTENSION	OPTIONAL FITTING(S)
ALARM	PUMP STAND

DRAWN	MPS	3/5/2008
CHECKED		
QA		
MFG		
DCL		
APPROVED		
DCL		
WEIGHT	1,705 kg (3,750 lbs)	LENGTH 26' 5"
OVERALL CAPACITY	54,552L (12,000 IG, 14,400 USG)	

TITLE		BX12000W UNDERGROUND FIBREGLASS WATER CISTERN	
 Drinking Water NSF/ANSI 61			
SIZE	C	DWG NO	BX12000W-00
SCALE		REV	
SHEET 1 OF 1			