

Parts List			
ITEM	QTY	PART NUMBER	DESCRIPTION
1	1	C-COLLAR-30IN	30"D COLLAR
2	1	C-SEAM-10FT	SEAM
3	4	LIFT-LUG-8-10	LIFT LUG
4	6	C-RIB	STRUCTURAL RIB
5	4	C-RIB-GUIDE	STRUCTURAL RIB WITH ANCHOR GUIDE

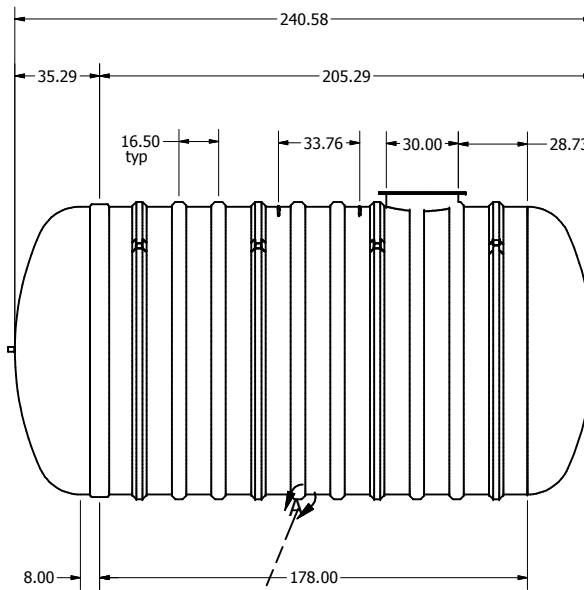
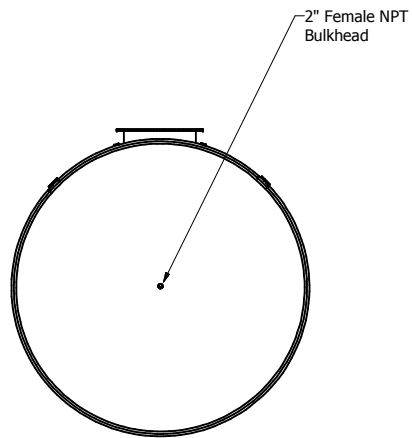
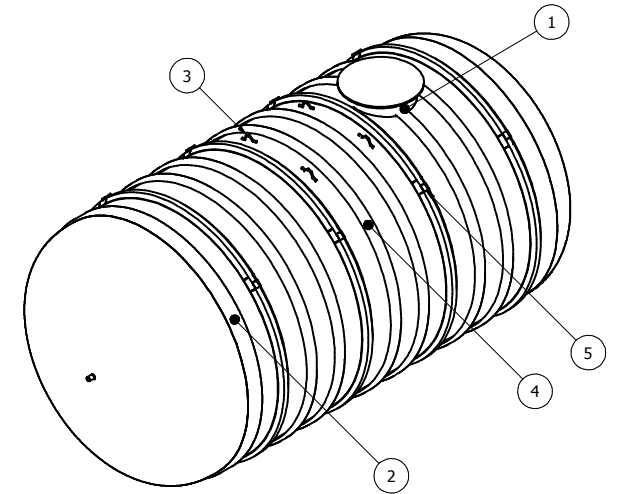
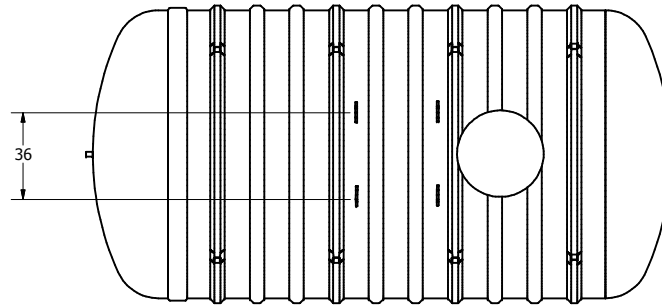

6mm x 200mm min. FRP bond on Outside

SECTIONAL JOINT DETAIL A
SCALE 1/25

OPTIONAL	PARTS
30"X12" EXTENSION	ANCHORS
30"X30" EXTENSION	FOAM INSULATION
30"X60" EXTENSION	LOCK BAR
30"X84" EXTENSION	OPTIONAL FITTING(S)
ALARM	PUMP STAND

DRAWN	MPS	2/27/2008
CHECKED		
QA		
MFG		
DCL		
APPROVED		
DCL		
WEIGHT	1,364 kg (3,000 lbs)	LENGTH 20' 1"
OVERALL CAPACITY	40,914L (9,000 IG, 10,800 USG)	

TITLE		BX9000W UNDERGROUND FIBREGLASS WATER CISTERN	
			
Drinking Water NSF/ANSI 61		SIZE	REV
		C	1
SCALE		DWG NO	BX9000W
		SHEET 1 OF 1	